

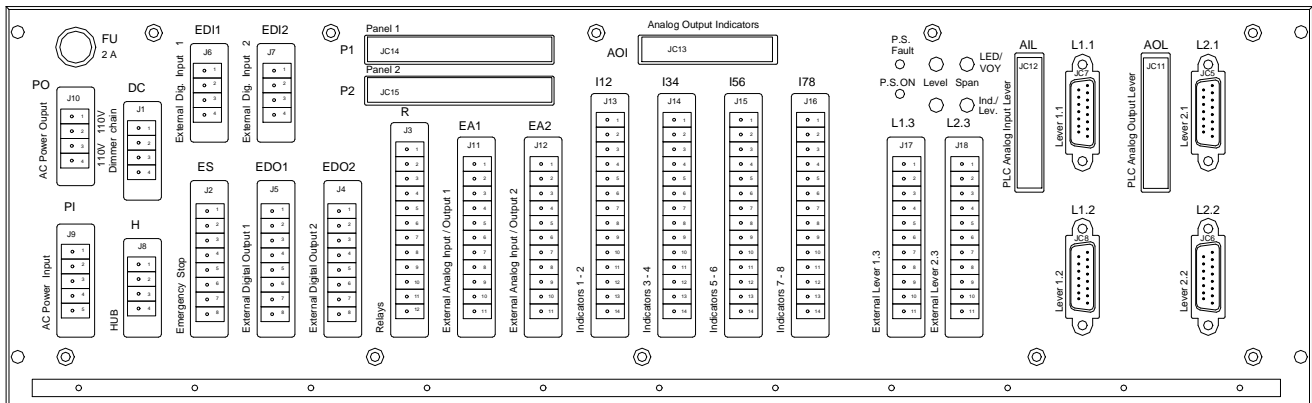

Marseille, 6 June 2002

POD Remote control Serial A
IPLC-6041

Technical Specification



Technical Specification

The remote control Serial A is embedded in size Europe rack.

It handles bridge between PLC and peripherals : Panel, Position indicators, lever motors and position potentiometers.

Main functions.

- Control light level panels, levers and indicators.
- Drive level motors via 4-20 mA current loop.
- Potentiometer cursor Measure position via 4-20 mA current loop.
- Provide PLC I/O 24V power supply.
- Provide HUB 24V power supply.
- Control Alarm Buzzers.

1 LINE POWER SUPPLY

The system can be powered on 110 V or 220V \approx 50/60 Hz. See drawing hereafter.

1.1 Power connection.

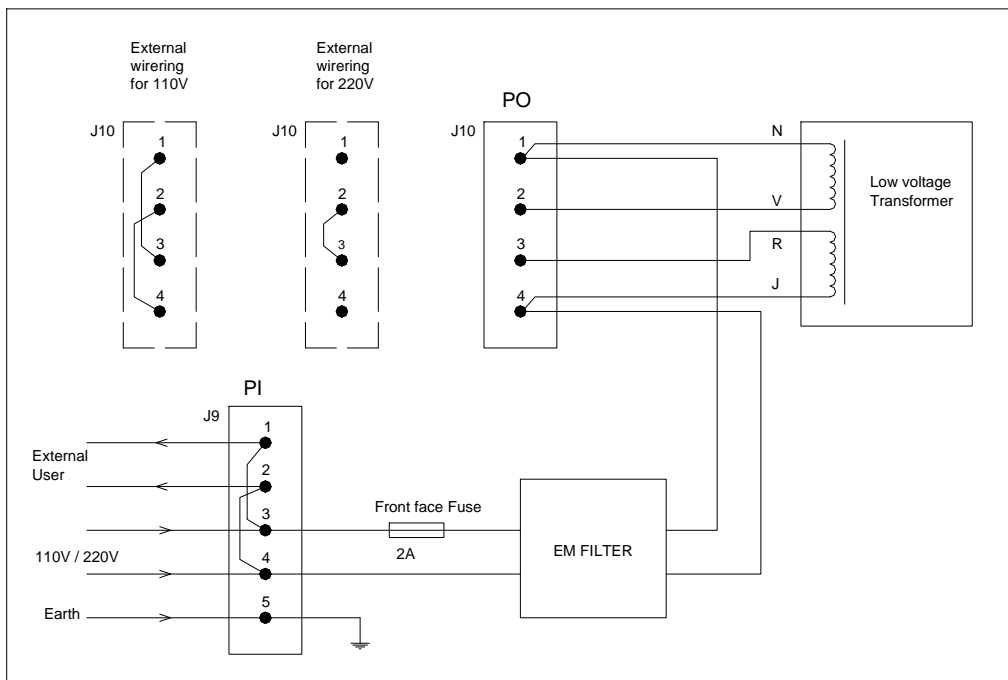

When system is powered, it turns ON green DEL "P.S. ON". The red DEL "P.S. Fault" must be OFF.

1.2 Safety :

A device watches all supplies provided by the rack. So, a drop down voltage does not occur an erratic move of levers motors.

In case of loosing one feeder supply, all supplies will be disconnected. The red LED "P.S Fault" will be turned ON and the green light will be turned OFF.

The HUB power is not affected by this mechanism.

To restart the system, it is only necessary to disconnect power supply until the red LED is turned OFF. Then the rack must be again powered.

1.3 hub

The rack provides 24V supply to the Hub. I max = 0,5 A.

	"H" connector
+24V hub	1
0V hub	2
K1.1 serial contact	3-4

2 AUXILIARIES CONNECTIONS

All ribbon cables are equipped with lock connector. All cables and ribbon cables can be plug in or extract when power is ON.

2.1 External Outputs

Direct connections Panels / front face connectors "EDI1" and "EDI2".

		"EDO1" connector
Panel 1	24	1
	23	2
	22	3
	21	4
	20	5
	+24V	6
	Dimmer Indicator	7
	0V	8

		"EDO2" connector
Panel 2	24	1
	23	2
	22	3
	21	4
	20	5
	+24V	6
	Dimmer Indicator	7
	0V	8

2.2 External Inputs

Direct connections Panels / connectors "EDI1" and "EDI2".

		"EDI1" connector
Panel 1	29	1
	28	2
+24V		3

Stop position levers contact "1.n".

			Sub D 15
Panel 1	25	Stop posit.	Lever 1.1 pin 4
	26	Stop posit.	Lever 1.2 pin 4
	27	Stop posit.	Lever 1.3 pin 4

		"EDI2" connector
Panel 2	29	1
	28	2
+24V		3

Stop position levers contact "2".

			Sub D 15
Panel 2	25	Stop posit.	Lever 2.1 pin 4
	26	Stop posit.	Lever 2.2 pin 4
	27	Stop posit.	Lever 2.3 pin 4

2.3 External outputs

		"EDO1" (connector J5)
Panel 1	24	1
	23	2
	22	3
	21	4
	20	5
	+24V	6
	Dimmer Indicator	7
	0V	8

		Bornier "EDO2" (connector J4)
Panel 2	24	1
	23	2
	22	3
	21	4
	20	5
	+24V	6
	Dimmer Indicator	7
	0V	8

2.4 Emergency stop

Direct connections Panels / connectors "ES".

		"ES" (connector J2)	
Panel 1	10		1
	11		2
	12		3
	13		4
Panel 2	10		5
	11		6
	12		7
	13		8

2.5 Relay

4 relays are energised through the two panels.

			"R" (Connector J3)	
			NO	NC
Panel 1	14	K1.1	1-2	2-3
	15	K1.2	4-5	5-6
Panel 2	14	K2.1	7-8	8-9
	15	K2.2	10-11	11-12

Cut off capability : 2A / 220V ≈.

2.6 Buzzers

The two 98dB buzzers are controlled by the panels.

In order to differentiate each one, the first buzzer one is driven by intermittent signal. Frequency : 5 hertz.

3 DIMMERS

The light level of the panels is controlled from one of two panels or from an external input. (Dimmer Chain connector). Sixteen different levels are available.

All controls are parallel wired.

Pin 7 (b1 Dimmer Chain connector) is common point.

Pin 8 (b2 Dimmer Chain connector) cause light goes down.

Pin 9 (b3 Dimmer Chain connector) cause light goes up.

If push action is keep on, one step (plus or minus) is implemented each ½ second.

Two power stages are controlled by adjustable gain and adjustable minimum level. The two stages are both driven.

The gains and minimum levels are modifiable by 4 trimmers mounted on the front face.

The "Line" LED is maximum powered and are not adjustable.

Dimmer	Min level ("Level")	Gain ("Span")	Current Limitation.	Outputs
Indicators / Levers	5V / 0 points	24V / 16 points	0,4 A	Indicators / Levers
Panel LED	10V / 0 points	24V / 16 points	2 A	Panels 1 et 2

4 LEVERS

The device ensures the potentiometer cursor position measurement and drives the levers motors. Levers 1.1, 1.2, 2.1 and 2.2.

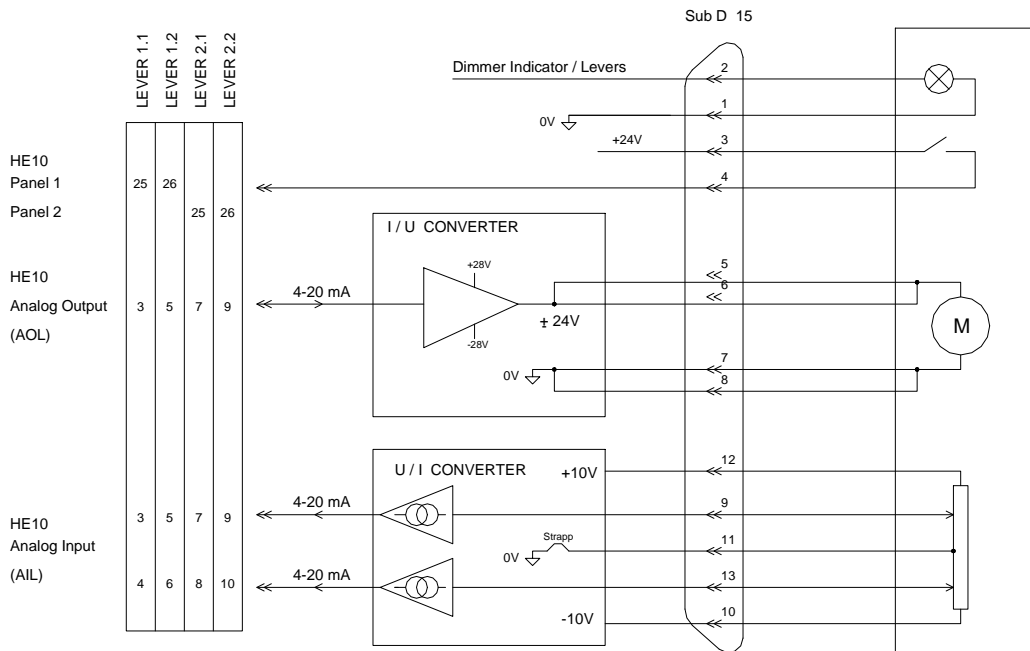

External Levers 1.3 and 2.3.

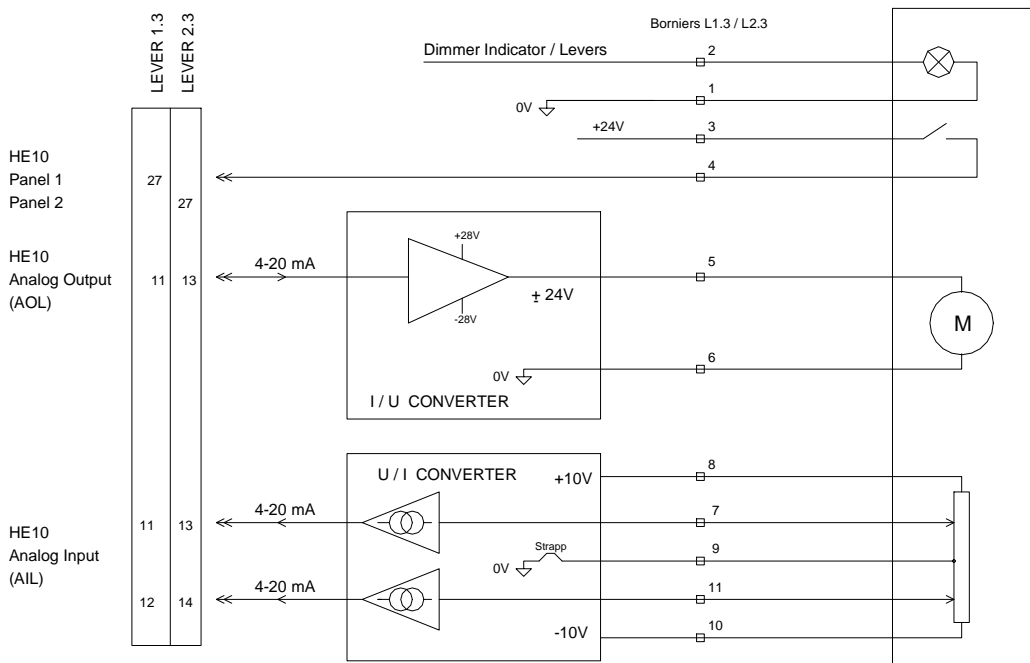

4.1 Cursor position measurement

The potentiometers (2K Ω) are supplied by internal $\pm 15V$.

For each potentiometer, a 500 Ω resistor is mounted in serial with +15V and a second 500 Ω resistor is mounted in serial with -15V. So, the voltage at the ends of potentiometers, allows to get $\pm 10V$ on the extreme cursor positions.

The voltage cursor is converted in current signal. $\pm 10V \rightarrow 4-20 \text{ mA} / 250 \Omega$.

Variation law : $V_e = \text{Input voltage (potentiometer cursor)}$.

V_e	$I_s \text{ mA}$
10	4.00
9	4.80
8	5.60
7	6.40
6	7.20
5	8.00
4	8.80
3	9.60
2	10.40
1	11.20
0	12.00
-1	12.80
-2	13.60
-3	14.40
-4	15.20
-5	16.00
-6	16.80
-7	17.60
-8	18.40
-9	19.20
-10	20.00

4.1.1 Cut wire detection

In case of wire disconnection, the device sets a current lower 4 mA. That current is detected as a fault by PLC.

The fault appears on the following conditions :

- One of potentiometer wire is cut.
- Cursor potentiometer wire is cut.
- Potentiometer plug is disconnected.

4.2 Motor levers command.

The motors are controlled by 4-20 mA issued from PLC.

Input current is converted in voltage via a 250 Ω resistor.

Ie	Ve
4 mA	1 V
12 mA	3V
20 mA	5V

Variation low . Vs = Output motor voltage.

Ie mA	Vs
4.00	24.0
4.80	21.6
5.60	19.2
6.40	16.8
7.20	14.4
8.00	12.0
8.80	9.6
9.60	7.2
10.40	4.8
11.20	2.4
12.00	0
12.80	-2.4
13.60	-4.8
14.40	-7.2
15.20	-9.6
16.00	-12
16.80	-14.4
17.60	-16.8
18.40	-19.2
19.20	-21.6
20.00	-24.0

4.2.1 Cut wire detection.

In case of input wire disconnection or PLC connector disconnection, the input signal is null. So, to avoid device drive the motor in maximal speed, the device sets output stage to 0V in order to not turn the motor.

5 Mounting

The rack is set up against a vertical panel. On rear face, 4 oblong holes are provided for \varnothing 6 mm screws holding the rack.

In order to allow a normal cooling of the rack, the rear face must be kept at a minimum 5 mm to mounting panel.

6 Features

Working temperature : 0 à 35°C.

Power supply : 110V / 220V \pm 20 %.

Consumption : 250 VA

Protection class : IP20.

7 Dimensions

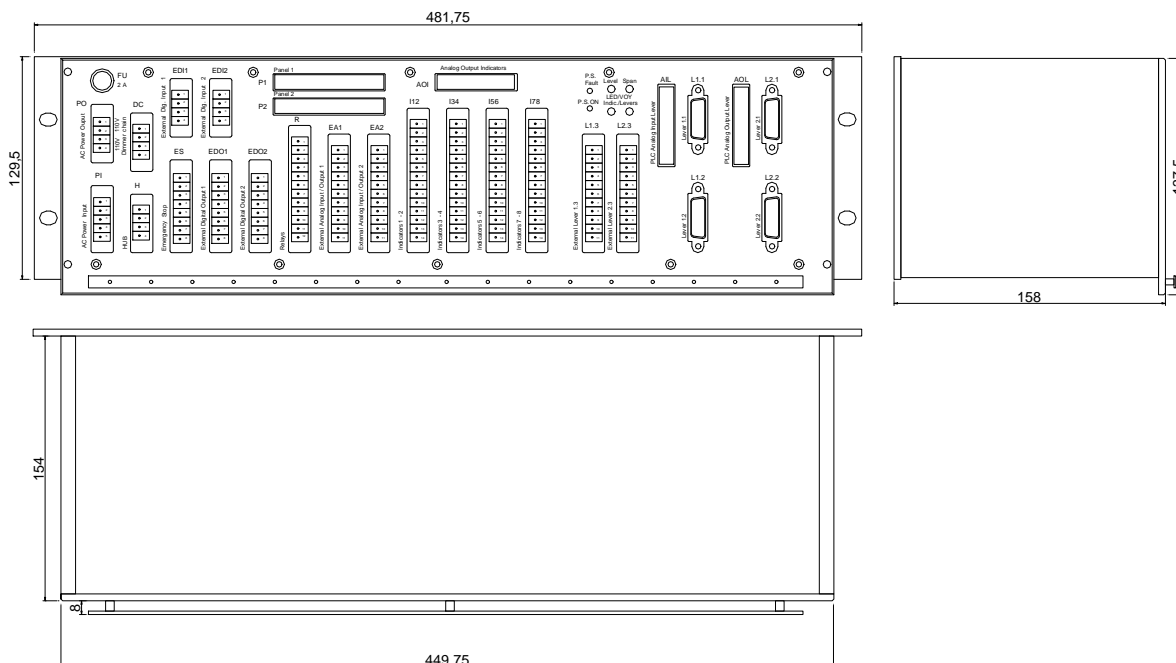

Weight : 8 Kg.